



- Sub miniature - only 21 x 10 x 11.6mm
- Up to 2A /30VDC rating
- DIL Pitch PCB mounting
- Cost effective

RoHS
Compliant ✓

Contacts

Contact arrangement	DPDT (2 Changeover); 2 Form C	
Contact material	Ag + Au plate (2um)	
Max. switching voltage	AC/DC	120VAC, 30VDC
Min. switching current / voltage	1mA/1VDC	
Rated load	AC1	1A, 120VAC
	DC1	2A, 24VDC
Max. switching power	120VA / 48W	
Initial resistance	≤ 100mΩ, max. at 0.1A/6VDC	

Coil

Rated voltage	DC	3...48V
Must release voltage	≥0.1U _n	
Operating range	See table 1	
Rated power consumption	DC	0.20W / 0.36W, 48V

Insulation

Insulation resistance	≥100MΩ at 500VDC, 50%RH	
Dielectric strength	coil to contact	1000Vrms, 1min
	contact to contact	500Vrms, 1min

General Data

Operating time	typ.	8ms, 0.2W / 6mS, 0.36W
Release time	typ.	4ms
Electrical life	ops.	1 x 10 ⁵
Mechanical life	ops.	1 x 10 ⁷

Environmental

Ambient temperature	operating	-30 to 80°C
	storage	-30 to 80°C
Shock resistance	functional	10g, 11ms
	destructive	100g
Vibration resistance	DA 1.5mm 10-55Hz	
Dimensions	L x W x H	21 x 10 x 11.6mm
Weight	approx.	≤ 4.8g

Ordering Code

D T C 2 - 8 2 1 2 - 8 5 - S 0 2 4

Series

Contact material

82: Ag + Au plate (2um)

Contact arrangement

12: DPDT (2 C/O)

Environmental protection

8: In cover, sealed IP64

Mounting & terminations

5: For PCB

Coil code:

See table 1

Coil Data

Table 1

Coil code	Nominal voltage (VDC)	Coil resistance (Ω) ±10%	Power consumption (mW)	Must operate voltage max. (VDC)	Must release voltage min. (VDC)	Max. allowable voltage (VDC)
S003	3	48	200	2.25	0.3	4.5
S005	5	125	200	3.75	0.5	7.5
S009	9	405	200	6.75	0.9	13.5
S012	12	720	200	9.00	1.2	18.0
S024	24	2880	200	18.00	2.4	36.0
1048	48	6400	360	36.00	4.8	72.0

Overall Dimensions mm

Fig. 1

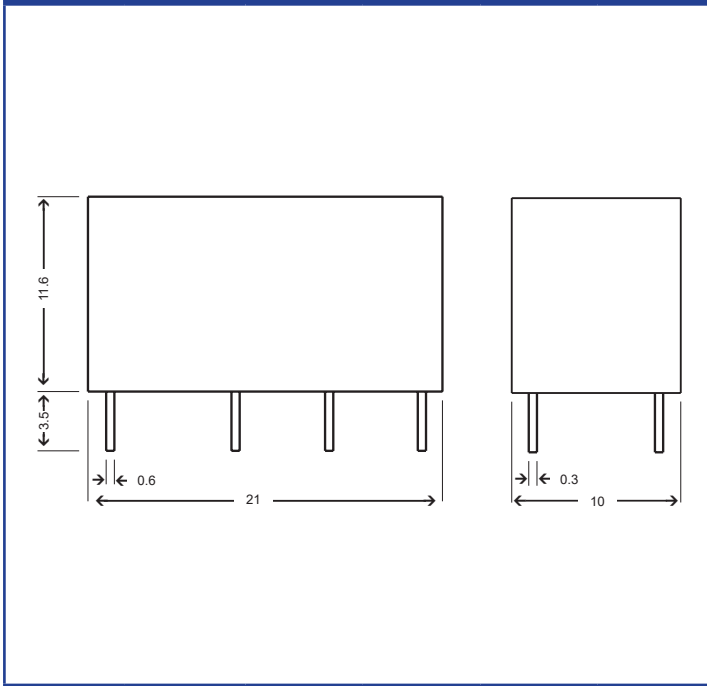

PCB Mounting Dimensions mm

Fig. 2

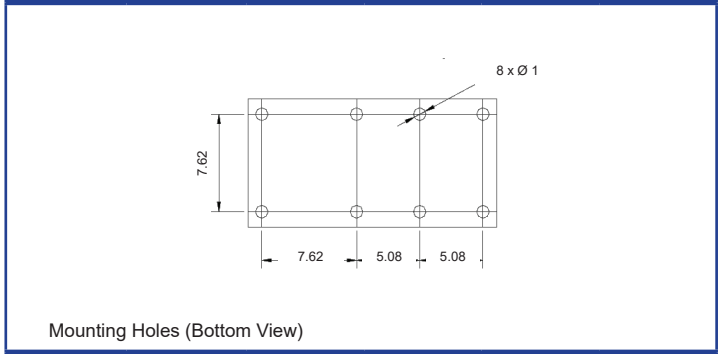

Wiring Diagrams mm (bottom view)

Fig. 3

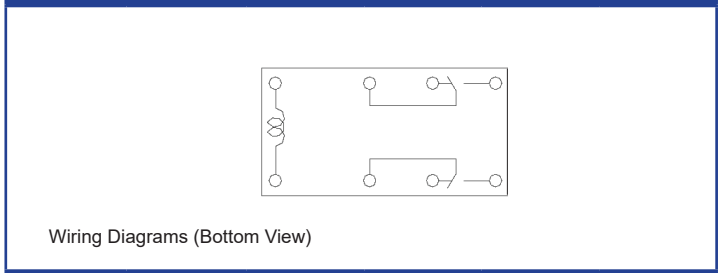

Reference Curves

Fig. 4

