



- HVDC 550A Continuous
- Max. switching current = 2000A
- Contacts sealed in inert gas
- Magnet arc blowout
- Auxiliary contact option
- PWM Coil economiser standard
- Female M6 or M8 male power terminals



Contacts

Contact arrangement	SPST-NO-DM	
Contact material	T2+Ag	
Max. switching voltage	AC/DC	1000VDC
Rated load	DC1	550A 1000VDC (break only above 350A)
Max. continuous thermal current	600s	650A (with 250mm ² conductors)
	60s	850A (with 250mm ² conductors)
Max switching current	1 time only	2000A 350VDC
Initial contact resistance	max.	1mΩ (at 1A)
Auxiliary contact (when fitted)	arrangement	SPST-NO (1 Form A), (SPST-NC by request)
	max. current	2A @ 30VDC / 3A @ 125VAC
	min. current	100mA @ 5VDC

Coil

Nominal voltage (see page 2)	DC	9~36VDC, 32~95VDC (with coil economiser)
Rated power consumption	hold	1.56W @ 12VDC

Insulation

Insulation resistance	initial	100MΩ (min.)
	life end	50MΩ (min.)
Dielectric strength	coil to contact	2500Vrms / 1mA / 1 min (at sea level)
	contact to contact	2500Vrms / 1mA / 1 min (at sea level)

General Data

Operate / bounce time at 20°C	max.	25ms / 7ms
Release time	max.	12ms
Electrical life	ops.	Voltage and current dependent - see fig. 1
Mechanical life	ops.	2 x 10 ⁵

Environmental

Environmental sealing	IP rating	Contacts are inside hermetically sealed can, economiser is protected by dust cover only.
Ambient temperature	operating	-40 to +85°C
Relative humidity		5 to 85%RH
Shock resistance		20G peak, 11ms 1/2 sine
Vibration resistance		20G sine peak (80 to 2000Hz)
Dimensions	L x W x H	58.2 x 80.48 (over flanges) x 72.11 (max.)
Weight	approx.	430g±10g

Ordering Code

D E V R 35 - 5 0 6 1 - S 8 - 0 9 3 6 - R 1

Series

Coil code:

See table 1

Contact material

50: T2+Ag

Contact arrangement

61: SPST-NO*

71: SPST-NO* + Auxiliary

81: SPST-NO

91: SPST-NO +Auxiliary

* Polarised see page 2

Mounting & terminations

Bottom flange mounting base

S8: M8 male stud power terminals

S9: M6 female thread power terminals

Coil & auxiliary contacts by flying leads

Coil wire length

R: 14.96" (380mm)

T: 5.9" (150mm)

Coil wire & auxiliary contact termination

1: None

2: Yazaki 7282-5558-10 Male

Other terminations to special order

Coil Data

Table 1

Coil code	Nominal voltage (VDC)	Must operate voltage max. (VDC)	Max. allowable voltage (VDC)	Must release voltage min. (VDC)	Inrush current Max. (A)	Hold voltage min. (VDC)	Holding current (average)
0936	9 - 36	9	36	6	3.8	7.5	130mA@12VDC 70mA @ 24VDC
3295	32 - 95	32	95	18	1.3	22	30mA @ 48VDC

PWM coil economiser standard, no additional coil surge suppression required.

Other voltages available upon special request and subject to minimum quantity.

Electrical Performance

Fig. 1

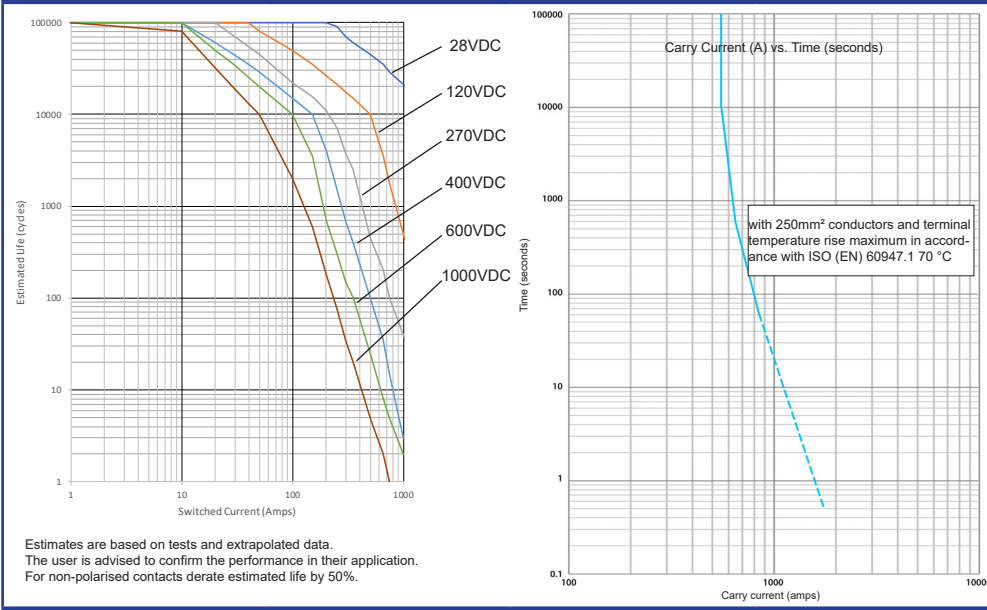

Circuit Diagram

Fig. 2

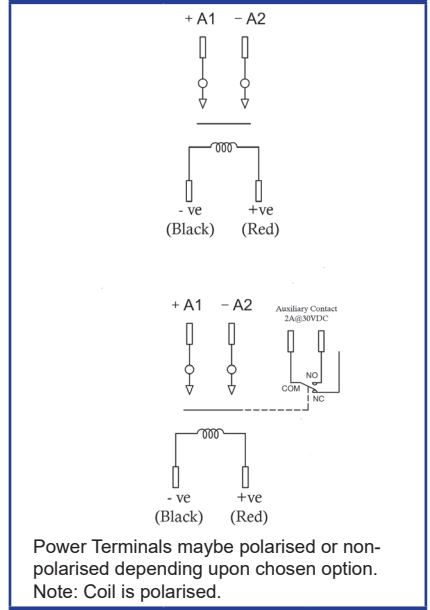

Dimensions

Fig. 3

