



- HVDC 1000A carry current (90s)
- Max. switching current = 2500A / 800VDC
- Contacts sealed in inert gas
- Magnet arc blowout
- Non-polarized power terminals
- Ceramic arc chamber
- Dual coil economiser as standard
- Auxiliary contact as standard



Contacts

Contact arrangement	SPST-NO-DM	
Contact material	Oxygen Free Copper	
Max. switching voltage	AC/DC	1500VDC
Rated load (resistive, $\cos \phi=1$)	DC1	600A 1500VDC (break only above 350A)
Max. continuous thermal current at 23°C ambient temperature	360s	800A (with 320mm ² conductors)
	90s	1000A (with 320mm ² conductors)
	5ms	8000A (with 320mm ² conductors)
Max switching current (1 time only)	V DC	800V 2500A / 1000V: 2000A / 1500V: 1000A
Initial contact volt drop	max.	0.3mΩ @ 20A / 6VDC
Auxiliary contact	arrangement	SPST-NO (1 Form A) (SPST-NC by request)
	max. current	2A @ 24VDC / 3A @ 125VAC
	min. current	100mA @ 8VDC

Coil

Nominal voltage (see page 2)	DC	12VDC, 24VDC (with dual coil economiser)
Rated power consumption	hold	<5W

Insulation

Insulation resistance	initial	≥ 1000MΩ (Min.) (1000VDC, 1 minute)
Dielectric strength	coil to contact	4000Vrms / ≤1mA / 1 min (at sea level)
	between main contacts, main & aux contacts	4000Vrms / ≤1mA / 1 min (at sea level)
	between open auxiliary contacts	750Vrms / ≤1mA / 1 min (at sea level)

General Data

Operate time at 23°C	max.	50ms (+ 5ms bounce time)
Release time at 23°C	max.	30ms
Electrical life	ops.	Voltage and current dependent - see fig. 1
Mechanical life	ops.	>2 x 10 ⁵
Capacitive make	(RC=1ms)	10,000 cycles, 500A peak at 50V

Environmental

Ambient temperature	operating	-40 to +85°C
Relative humidity		5 to 85% RH
Altitude		≤4000m (derate by 0.83 between 3000 & 4000m)
Shock resistance	impact	>50G, 490m/s ² 6ms ½ sine
	stability	>20G, 11ms ½ sine (malfunction <10µs)
Vibration resistance	sine wave	>5G, 49m/s ² , 10Hz ~ 500Hz (malfunction <10µs)
Dimensions	L x W x H	104 x 70 x 108.1mm (max.)
Weight	approx.	1100g

Ordering Code

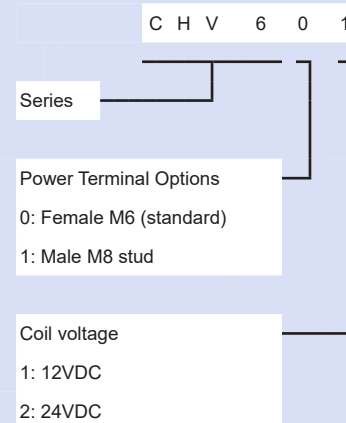

Coil Data

Table 1

Order code	Nominal voltage (VDC)	Must operate voltage max. (VDC)	Max. allowable voltage (VDC)	Must hold voltage max.* (VDC)	Must release voltage min. (VDC)	Inrush Current ±10% (A)	Hold Current ±10%(A)	Rated Coil Power
CHV601 CHV611	12	9	16	7.8	1.2	4.2	0.42	5W (Hold)
CHV602 CHV612	24	18	32	15.6	2.4	2.1	0.21	50W, 0.2s (Operate)

Twin coil economiser standard. No additional coil back emf suppression required. Other coils available upon special request.

* Max. Non-release voltage @ 85°C and max. continuous current load, pre-energized at 1.1Un

Electrical Performance

Fig. 1

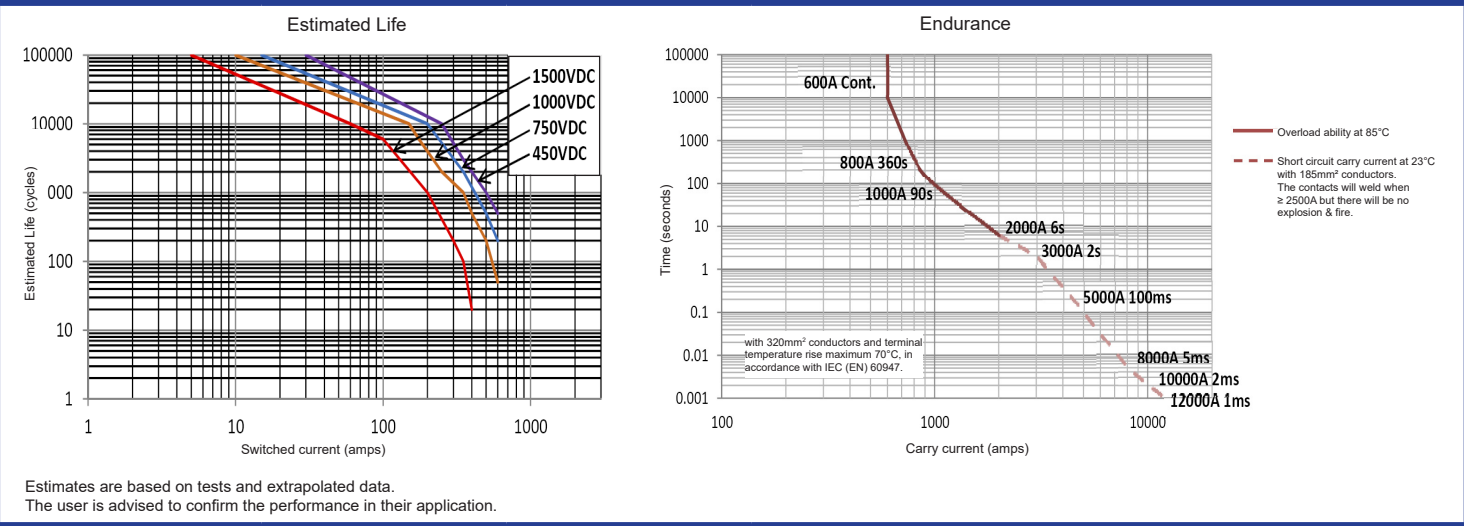

Dimensions

Fig. 2

Circuit Diagram

Fig. 3

